



**GOVERNMENT OF TELANGANA
 TELANGANA DRINKING WATER SUPPLY PROJECT
 Rural Water Supply & Sanitation Department**

TELANGANA WATER GRID



**L&T Construction - Water, Smart World & Communication
 CHENNAI**

CLIENT: RURAL WATER SUPPLY AND SANITATION DEPARTMENT (WATER GRID), TELUNGANA.	CONSULTANT : WAPCOS LIMITED
---	---------------------------------------

PROJECT :	PROVIDING DRINKING WATER TO HABITATIONS IN KOMARAMBHEEM ASIFABAD SEGMENT IN ADILABAD DISTRICT
------------------	---

SUPPLIER / CONTRACTOR:	L&T Construction, Water, Smart World and Communication
-------------------------------	--

JOB Ref. No. : LE150883	TITLE : DESIGN OF SUMP - 10KL CAPACITY ALIGUDA3 AT SIRPUR-U MANDAL																
<table border="1"> <thead> <tr> <th></th> <th>NAME</th> <th>SIGN</th> <th>DATE</th> </tr> </thead> <tbody> <tr> <td>DSGN</td> <td></td> <td></td> <td></td> </tr> <tr> <td>CHKD</td> <td></td> <td></td> <td></td> </tr> <tr> <td>APPD</td> <td></td> <td></td> <td></td> </tr> </tbody> </table>			NAME	SIGN	DATE	DSGN				CHKD				APPD			
		NAME	SIGN	DATE													
DSGN																	
CHKD																	
APPD																	

DOC./DRG. No. L E 1 5 0 8 8 3 - C - W S - R W - D C - 1 4 5 0	SIZE A4	REV. A
---	-------------------	------------------

RELEASED FOR	<input type="checkbox"/> PRELIMINARY	<input type="checkbox"/> INFORMATION	<input checked="" type="checkbox"/> APPROVAL	<input type="checkbox"/> CONSTRUCTION
---------------------	--------------------------------------	--------------------------------------	--	---------------------------------------

Submitted sir,

Sub:RWS&S-TDWSP- Vadoni 10KL clear water sump in Sirpur-U Mandal–Komarambheem Asifabad Segment-Adilabad District-Designs -Approval-Reg.

Kindly pursue the Designs of the following 10KL Clear Water sump at Aliguda 3 (V), Sirpur-U(M), submitted by the Executive Engineer TDWSP Asifabad Division, Adilabad district for approval.

1. 10KL Clear Water Sump.

The Executive Engineer TDWSP Asifabad Division has submitted Structural Designs & Drawings of 10KL Clear Water sump based on the field conditions and as per the estimate provisions, the structural designs & drawings for the above structure is verified with RWS&S standard Type Designs and submitted for approval.

The following design parameters were considered:

- Capacity : 10KL
- Net SBC of Soil : 10.0 t/sqm
- Grade of concrete & Steel : M 30 & Fe 500
- Dia of sump Inner to Inner : 3 .00m
- Sidewall Height : 1.90mts
- Sidewall Thickness: ~~150mm~~ 200mm *df*
- Top Slab thickness: 150 mm
- RaftSlab thickness: 200mm

As per the above parameters the structural design and drawings of the clear water sump is verified, as per similar Type designs available and approved by the RWS&S Department considering the SBC and type of soil, duly following IS codes, IS: 456-2000, SP:16, 34, IS:3370 and IS 1893-2002 (seismic codes).The sizes and steel proposed in the designs and drawings of all components are safe and sufficient.

The additional points noted after checking the designs are:

- Detailed Estimate of the Structure with these specifications has to be prepared and compared with the provision made in sanctioned estimate. Such that deviation if any is within authorized limits. If any deviations noticed, the Estimate should be submitted for obtaining approval from the Competent Authority.

Subject to approval a draft memo addressed to the EE, TDWSP Asifabad Division , for communicating approved Structure is put up for kind perusal and approval.

AP
AEE (Designs)
TDWSP, Nirmal Circle

AS
DEE (Designs)
TDWSP, Nirmal Circle

P 30/4/16
Superintending Engineer,
TDWSP, Nirmal Circle

DESIGN CALCULATION

PROJECT TITLE

PROVIDING DRINKING WATER TO HABITATIONS
IN KOMARAMBHEEM ASIFABAD SEGMENT
IN ADILABAD DISTRICT (30 MLD WTP)

UNIT

10 KL SUMP

DCI NO: - LE150883-C-WS-RW-DC-1442
&
LE150883-C-WS-RW-NU-1443

PRINCIPAL CLIENT

RURAL WATER SUPPLY
AND
SANITATION DEPARTMENT,
TELANGANA

CONTRACTOR

L&T CONSTRUCTION
WATER & EFFLUENT TREATMENT SBG

DESIGN OF SUMP

BASIC DATA

Diameter = 3 m
Water depth = 1.6 m
Free board = 0.30 m

CAPACITY CHECK

Required capacity = 10 KL

Capacity of suction

Clear diameter = 3 – 2 x plaster thickness
= 3 – 2 x 0.012
= 2.976 m

Water depth = 1.6 m

Volume = $(\pi * d * d / 4) * H$
= $(\pi * 2.976 * 2.976 / 4) * 1.6 = 11.13 \text{ m}^3$ (including dead storage)

Volume-Dead storage = 11.13-1.04 = 10.09

Net volume = 10.09 $\text{m}^3 > 10 \text{ m}^3$, hence O.K.

ELEMENT:

Inside tank: (1) Cylindrical wall
(2) Top Slab

SBC – 10 t/m²

GROUND WATER TABLE: NO GWT

SUMP : 10 KL			FORMULA	
PROJECT: PROVIDING DRINKING WATER TO HABITATIONS IN KOMARAMBHEEM ASIFABAD SEGMENT IN ADILABAD DISTRICT (30 MLD WTP)	SUMP AT	CLIENT	RURAL WATER SUPPLY AND SANITATION DEPARTMENT, TELANGANA	
	Different village			
STRUCTURE	DESIGN CALCULATION FOR SUMP	DATE	REV	0
		2/2/2016		
DESIGN CALCULATION DATA				
General Data	Sumpcap	10.000	m ³	As per tender Specification
Required Capacity of Sump				
Location				
Hydraulic Features	GL	0.00	m	
Ground Level	Ds	0.15	m	
Dead Storage	FB	0.30	m	
Free Board				
Basic Shape :	Circular with flat slab			
Material Data	uwc	25.000	KN/m ³	
unit weight of concrete	uww	10.000	KN/m ³	
unit weight of water	uwp	21.000	KN/m ³	
unit weight of plaster				
load Data	lrf	1.500	KN/m ²	
live load at roof slab	Fl	1.000	KN/m ²	
Finish load				
Geometry Data	Dia	3.00	m	
Diameter				
Depth of tank above GL		0.90		
Depth of tank below GL		1.00		
Water depth : With Dead storage	Wd	1.60	m	
Top Slab thickness	Tstkh	0.150	m	

Bottom slab thickness	Bsthk	0.200	m
plaster thickness	pt	0.012	m
Permissible stress (As per IS 456 & IS 3370)			
Concrete	fck	30	N/mm ²
Concrete grade -FCK	fckc	8.0	N/mm ²
per. stress in con. for direct comp	fckbc	10.0	N/mm ²
per. stress in con.in com.due to bending	fckt	1.5	N/mm ²
per. stress in con. for direct tension	fcktb	2.0	N/mm ²
per. stress in con. In ten due to bending	em	2.74E+04	N/mm ²
modulus of elasticity for container	fy	50045	N/mm ²
Reinforcement	fyc	130	N/mm ²
per. Ten. str.- steel tension due to bending	fyuc	130	N/mm ²
per. Ten. str.- steel tension due to direct ten	md	9.33	
Modular ratio	Dmin	15.0	m
Dimension for minimum steel	g	9.810	
Mass & Wt relation factor			
[A] CAPACITY OF CONTAINER			
Volume Calculation			
Water Depth with Dead Storage	Wdd	1.600	
Inside Diameter		3.000	
Clear Inside Diameter without plaster	Diac	2.976	
total volume	vt	11.13	m ³
dead storage	vdd	1.04	m ³
net volume	vn	10.09	m ³ > 10,000 OK
[B] TOP SLAB DESIGN			
Concrete grade	Fck	30	N/mm ²
Steel	Fy	415	N/mm ²
Clear cover	Cv	45	mm
Slab Diameter	Lx	3.000	m
Slab type	St	1	Simply supported

Width	B	1000 mm
Depth	D	150 mm
Maximum Bar dia	Db	10 mm
Density of concrete	Wd	25 kN/m ³
Loading		
Live load	LI	1.5 kN/m ²
Finishing load	FI	1 kN/m ²
CALCULATION		
Calculation of loading		
Self wt (Dead load)	DI	3.75 kN/m ²
Total Load	TI	6.25 kN/m ²
Effective depth	De	100 mm
Bending Moment	Bm	1.758 kN-m
Modular ratio		9.33
K	k	0.42
j = 1-k/3	j	0.9
Ast		157.1 mm ²
Provide : 10 dia - 200 c/c		
[C] CYLINDRICAL WALL		
inner diameter	cyid	3.000 m
top thickness	cyft	0.150 m
bottom thickness	cybt	0.150 m
Water depth	cyh	1.600 m
coefficient of constant height	cyc	0.000
free board		0.300 m
height of wall fir design	cyhh	1.600 m
increment in thickness	cyth	0.000 m
Hoop Force ; Wall free at Top and hinge at bottom condition		
F = $\text{coe} \times H \times D / 2$		
F= Hoop force		

H = Height of water above that section
 D = Diameter of wall at that section

Ration H^2/DT 5.689
 Enter Value for Auto serach 8.000

h

hoop force

	sr. no	depth from top in meter	thickness at section	coeffient	hoop force in wall = Coe. X rad * height * unit wt of liquid	area of steel required = force / 1300	actual tensile stress in concrete = force/(thk*wid	Minimum Area of steel in mm2 on each face
	sr. no	area of steel requid	dia of bar	bar spacing	area of steel prod			
Minimum % steel as per IS 3370-2009	1	0.160	0.150	0.010	0.2	2	0.002	180
	2	0.320	0.150	0.106	2.6	20	0.016	180
	3	0.480	0.150	0.227	5.4	42	0.035	180
Maximum Dimension	4	0.640	0.150	0.347	8.3	64	0.053	180
3.000	5	0.800	0.150	0.465	11.2	86	0.071	180
Permissible dimension for 0.24 % steel	6	0.960	0.150	0.565	13.6	104	0.087	180
15.000	7	1.120	0.150	0.632	15.2	117	0.097	180
	8	1.280	0.150	0.631	15.2	117	0.097	180
Minimum Steel	9	1.440	0.150	0.533	12.8	98	0.082	180
0.240	10	1.600	0.150	0.317	7.6	58	0.049	180
	1	180.000	10	200	785			
	2	180.000	10	200	785			
	3	180.000	10	200	785			
	4	180.000	10	200	785			
	5	180.000	10	200	785			
	6	180.000	10	200	785			
	7	180.000	10	200	785			
	8	180.000	10	200	785			
	9	180.000	10	200	785			
	10	180.000	10	200	785			

weight of wall straight part tapered part plaster total weight	cyspw cypfw cypfw tley	59.4 0.0 4.5 63.9	kN kN kN kN	$=Pl(*) (cyid+cytt) * cyh * cytt * uwc$ $=Pl(*) (cyid+cytt+(cybt-cyft)/3) * cyh * (1-cye) * (cybt-cyft)/2 * uwc$ $=(cyid-pt) * Pl(*) * pt * (trdd+cyh+mrrd/2-cyxa) * uwp$ $=cyspw+cypfw+cypfw$									
Maximum moment in wall				sr. no	depth from top in meter	thickness at section	coefficient	moment in wall = Coe. X height*3 * unit wt of liquid	effective depth m	Area of steel required	Minimum Area of steel in mm2		
Minimum % steel as per IS 3370-2009	1	0.160	0.150	0.00013	0.005	0.095	0	180					
Maximum Dimension #REF!	2	0.320	0.150	0.00046	0.019	0.095	2	180					
Permissible dimension for 0.24 % steel 15.000	3	0.480	0.150	0.00105	0.043	0.095	4	180					
Minimum Steel #REF!	4	0.640	0.150	0.00221	0.091	0.095	8	180					
	5	0.800	0.150	0.00364	0.149	0.095	13	180					
	6	0.960	0.150	0.00500	0.205	0.095	18	180					
	7	1.120	0.150	0.00535	0.219	0.095	20	180					
	8	1.280	0.150	0.00287	0.118	0.095	11	180					
	9	1.440	0.150	-0.00463	-0.190	0.095	-17	180					
	10	1.600	0.150	-0.01979	-0.811	0.095	-73	180					
Vertical steel as compression only, I provide min r/f area of steel required total on both face	sr. no	area of steel requd	dia of bar	bar spacing	area of steel prod	distance							
	1	180.000	10	200	393	0.160							
	2	180.000	10	200	393	0.320							
	3	180.000	10	200	393	0.480							
	4	180.000	10	200	393	0.640							
	5	180.000	10	200	393	0.800							
	6	180.000	10	200	393	0.960							
	7	180.000	10	200	393	1.120							
	8	180.000	10	200	393	1.280							
	9	180.000	10	200	393	1.440							
	10	180.000	10	200	393	1.600							

FOUNDATION DESIGN

WALL FOOTING DESIGN			
PROJECT: ADILABAD W.S.S		P16-2	
UNIT : 10 KL Sump			
WALL TYPE 1		W1	
BASIC DATA			
Density of water	denwt	10	kN/m3
Density of soil	denso	18	kN/m3
Density of concrete	decon	25	kN/m3
Angle of Repose	Phi	30	degree
Safe bearing capacity of soil	Sbc	100.0	kN/m2
Concrete grade	Fck	30	N/mm2
Steel grade	Fy	415	N/mm2
Depth below Gl	Dbg	1.00	m
Water depth	wtd	1.60	m
free board	fb	0.30	m
Wall above Ground		0.90	m
Clear cover	Cv	50	mm
Maximum size of bar dia	Db	12	mm
Water depth with free board	Wd	1.90	m
minimum % steel	pt	0.24	%
Moment			
Due to Water	Mtw	1.00	kN-m (From Analysis Result)
Wt from top dome/slab/column/wall	Slabwt	5.00	kN-m
Wall geometry			
Straight portion	lb	1.900	m
Tapered portion	lc	0.000	m
	tb	0.150	m
	td	0.150	m
Footing geometry			
Toe projection	ht	0.250	m
Heel straight projection	hh1	0.450	m
Heel tapered projection	hh2	0.000	m
Thickness at toe (free end)	tta	0.200	m
Thickness at toe (fwall face)	tth	0.200	m
Thickness at heel (wall end)	tha	0.200	m
Thickness at heel (free face)	thb	0.200	m
Total Height of Wall	Tlw	1.900	m
Total length of wall footing	wf	0.850	m

Design of Toe - At Point A

Moment at face of outer wall			
Due to rectangle diagram	Mreco	0.97	kN-m
	Mtrio	0.05	kN-m
Total moment due to upward pressure		1.02	kN-m
Net moment at A from Toe side	Toem	1.02	kN-m
Thickness at toe		200	mm
Effective depth	DefToe	144	mm
Ast required =		60.61	mm ²
Check for minimum steel			
top		240	mm ²
bottom		0	mm ²
Design Steel			
Main steel - Top		240	mm ²
Main steel - bottom		61	mm ²
Distribution steel - top		240	mm ²
Distribution steel - bottom		0	mm ²

Design of heel : At point B & C

Design at point B			
Due to rectangle diagram (upward)	Mrecl	2.55	kN-m
	Mtril	0.15	kN-m
Total Upward moment		2.70	kN-m
Due to water (down ward)		1.92	kN-m
Net downward moment at B from heel side	heelm	0.77	kN-m
Thickness Provided		200	mm
	defheel	144	mm
Ast required =		46	mm ²
Check for minimum steel - straight portion			
top		240	mm ²
bottom		0	mm ²
Design Steel			
Main steel - Top		240	mm ²
Main steel - bottom		0	mm ²
Distribution steel - top		240	mm ²
Distribution steel -bottom		0	mm ²

Design at point C			
Due to rectangle diagram (upward)	Mrecl	0.00	kN-m
	Mtril	0.00	kN-m
Total Upward moment		0.00	kN-m
Due to water (down ward)		0.00	kN-m
Net downward moment at B from heel side	heelm	0.00	kN-m
Thickness Provided		200	mm
	defheel	144	mm
Ast required =		0	mm ²
Check for minimum steel - tapered portion			
Average thickness	thav	0.20	m
top		240	mm ²
bottom		0	mm ²
Design Steel			
Main steel - Top		240	mm ²
Main steel - bottom		0	mm ²
Distribution steel - top		240	mm ²
Distribution steel -bottom		0	mm ²

SUMMARY

Pressure Check

1>	P/A + M/Z	33.5	<	100	OK
2>	P/A - M/Z	25.2	>	0	OK

Reinforcement

	AstR	dia	spc	+	dia	spc	Astp	
Toe								
Top - main	240	10	200		0	0	393	OK
Bottom main	61	10	200		0	0	393	OK
Top - Dist	240	10	200		0	0	393	OK
Bottom - Dist	0	10	200		0	0	393	OK
Heel Straight portion								
Top - main	240	10	200		0	0	393	OK
Bottom main	0	10	200		0	0	393	OK
Top - Dist	240	10	200		0	0	393	OK
Bottom - Dist	0	10	200		0	0	393	OK
Heel tapered portion								
Top - main	240	10	200		0	0	393	OK
Top - Dist	240	10	200		0	0	393	OK
Bottom - Dist	0	10	200		0	0	393	OK

Gaithred
Asst. Executive Engineer
 TDWSP Asifabad

Dy. Executive Engineer
 TDWSP Asifabad

rae
Executive Engineer
 TDWSP Asifabad

ae

APPROVED
P. J. M. H. B.
 on **SE, NIRMAL**

NAME OF VILLAGE				
KOLAMGUDA	MADHARAMGUTTA	GOONDUGUDA	GOVARGUDA	BABAPUR
DODDIGUEM	OTTIGHAT	NAYAKAPPUGUDA	GOTTIGOONDUGUDA	PAVUGUDA
OOTPALLI	BHEEM GUDA	KONDI GG	SOMIGUDA	ALIGUDA 3
NAYAKAPPU GUDA	PATHAGUDA	KANNEPALLY	RAJULAGUDA	KHILADIGAON

SCHEDULE OF PIPE	
INLET PIPE SIZE	-
OUTLET PIPE SIZE	-
OVER FLOW PIPE SIZE	-

- NOTES-
- 1 ALL DIMENSION ARE IN MM AND LEVELS ARE IN METER.
 - 2 ALL CONCRETE MIX M:30 WITH MAXIMUM FREE WATER CEMENT RATIO OF 0.45 AND MAXIMUM CEMENT CONTENT OF 400kg/m³ FOR WATER RETAINING STRUCTURE.
 - 3 ALL CONCRETE SHALL BE MACHINE MIXED AND MACHINE VIBRATED.
 - 4 # - INDICATE HYSD-TMT BAR FE-415 GRADE 1 CONFORMING TO IS 1786-LATEST REVISION.
 - 5 CLEAR COVER TO MAIN STEEL 50mm IN BOTTOM SLAB & 25mm IN BEAM, TOP SLAB & WALL.
 - 6 FOUNDATION SHALL REST ON IN-SITU SOIL AND IT SHALL NOT BE ON FILLING MATERIAL I.E. MADE UP SOIL OR HIGHLY COMPRESSIBLE SOIL.
 - 7 BACK FILLING SHALL BE DONE IN WELL COMPACTED AND WELL WATER LAYER NOT EXCEEDING 150mm IN DEPTH.
 - 8 SBC CONSIDERED IN DESIGN IS 10 T/M² & NO GROUND WATER TABLE.
 - 9 INLET & OVERFLOW PIPE SHALL BE DECIDED AS PER SITE CONDITION.
 - 10 LOCATION & LEVELS OF INLET, OUTLET & OVERFLOW PIPE SHALL BE VERIFY WITH ENGINEER INCHARGE BEFORE EXECUTION.

LAP LENGTH SECHDULE	
DIA OF BAR	LAP LENGTH "L" IN mm
8	320
10	400
12	480
16	640
20	800
25	1000

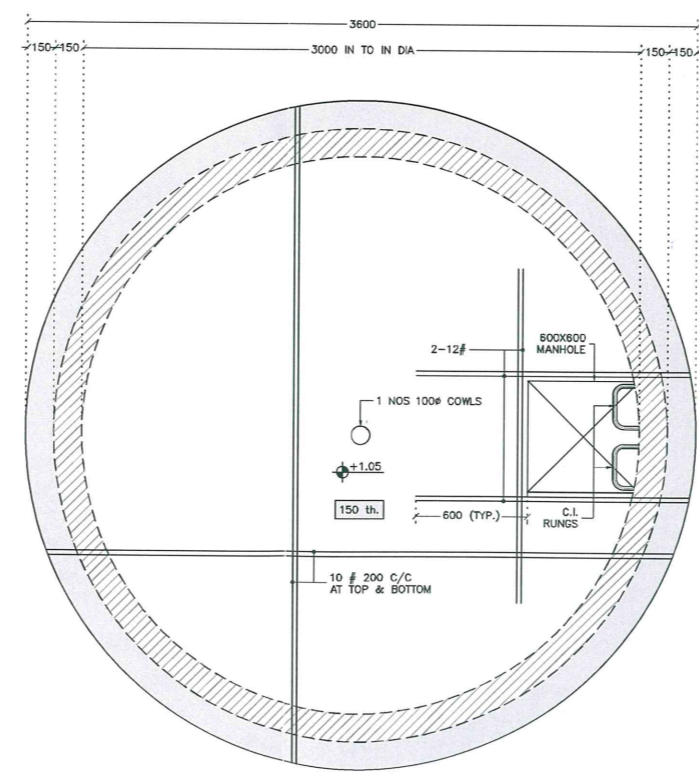
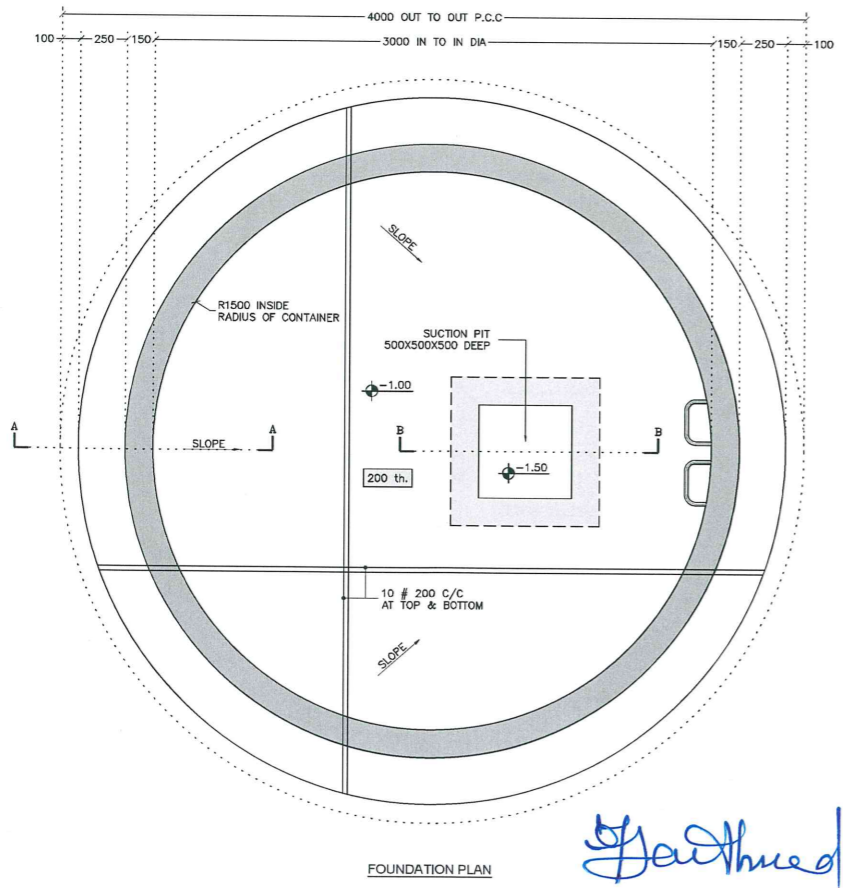
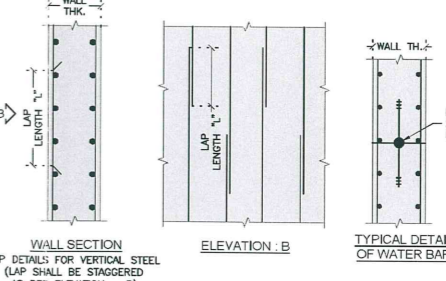
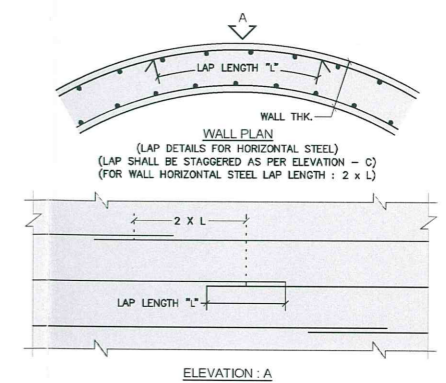
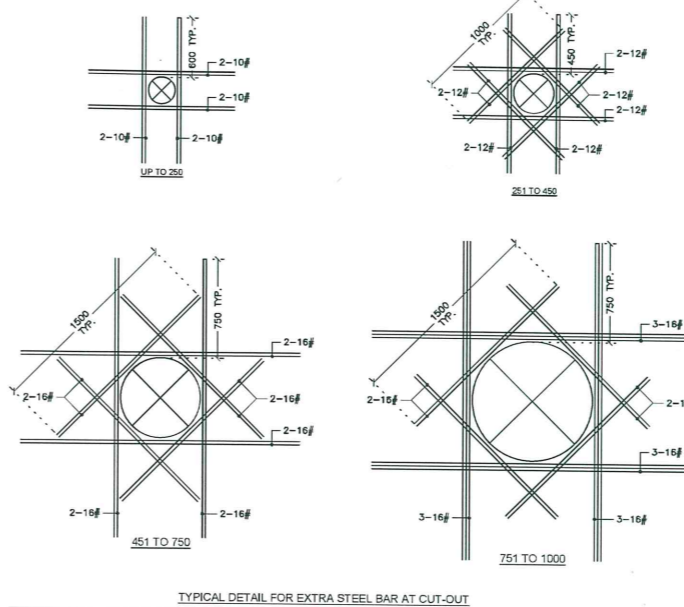
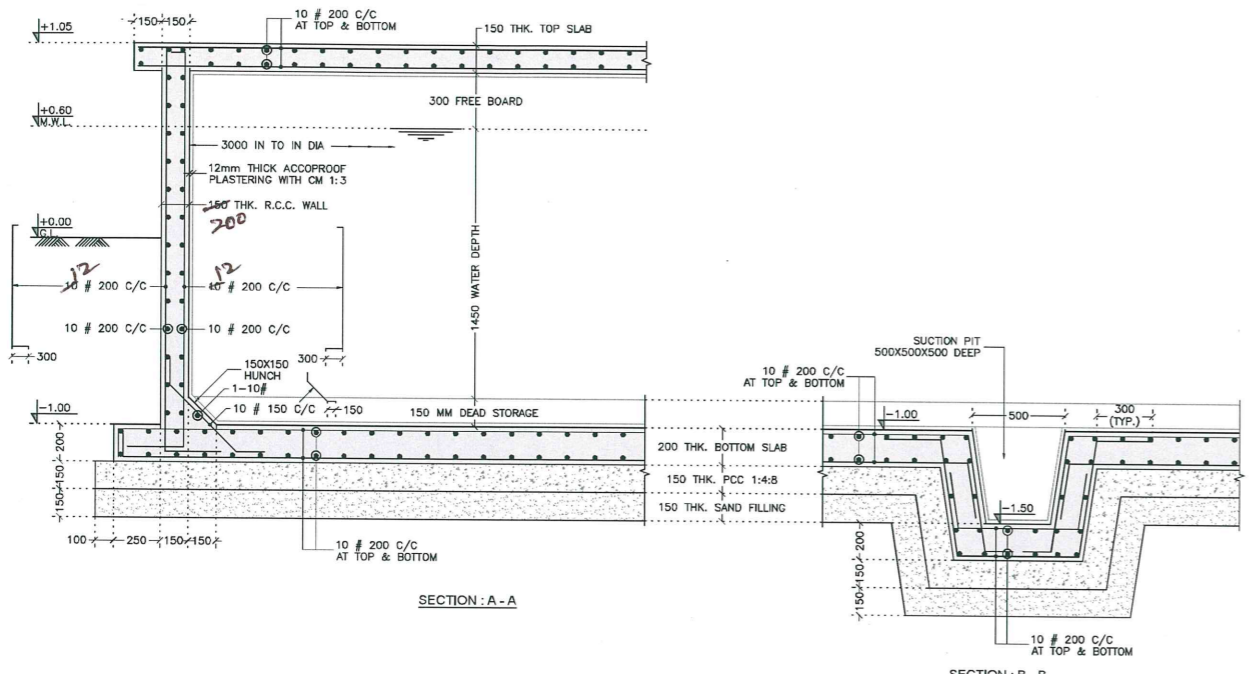

APPROVED
P30/14/16
 SE, NIRMAL

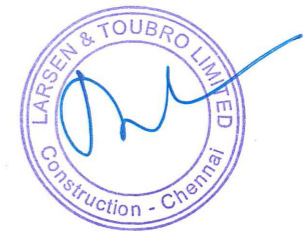

REV. No	DESCRIPTION	DATE	DESIGNED	DRAWN	CHECKED	APPROVED
A	FOR APPROVAL	02/02/16	HMP	NSP	RMM	-

REVISIONS

L&T Construction
 Water, Smart World & Communication.

CLIENT: RURAL WATER SUPPLY AND SANITATION DEPARTMENT, TELANGANA. CONSULTANT: L&T Construction

PROJECT: PROVIDING DRINKING WATER TO HABITATIONS IN KOMARAMBHEEM ASIFABAD SEGMENT IN ADILABAD DISTRICT

SUPPLIER / CONTRACTOR: L&T Construction Water & Effluent Treatment SBG

JOB No.: LE150883 TITLE: 10KL CAPACITY SUMP AT DIFFERENT VILLAGE (STRUCTURAL DETAILS) SCALE: 1:25

NAME	SIGN	DATE
DSGN HMP		02-02-16
DRWN NSP		02-02-16
CHKD RMM		02-02-16
APPD -		02-02-16

DRAWING No. LE150883-C-WS-RW-RC-1444 SIZE: A2 REV. A
 COMP. DATA: P16-02-79-02-01 SHEET 1 OF 1

RELEASED FOR: PRELIMINARY TENDER INFORMATION APPROVAL CONSTRUCTION

Garthmed
 Asst. Executive Engineer
 TDWSP Asifabad

nae
 Executive Engineer
 TDWSP Asifabad

Dy. Executive Engineer
 TDWSP Asifabad

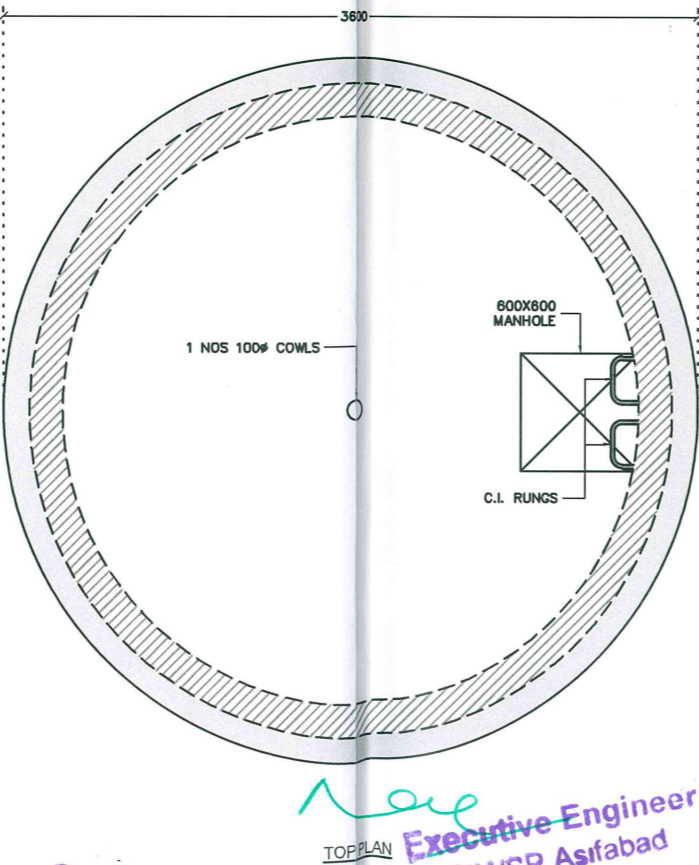
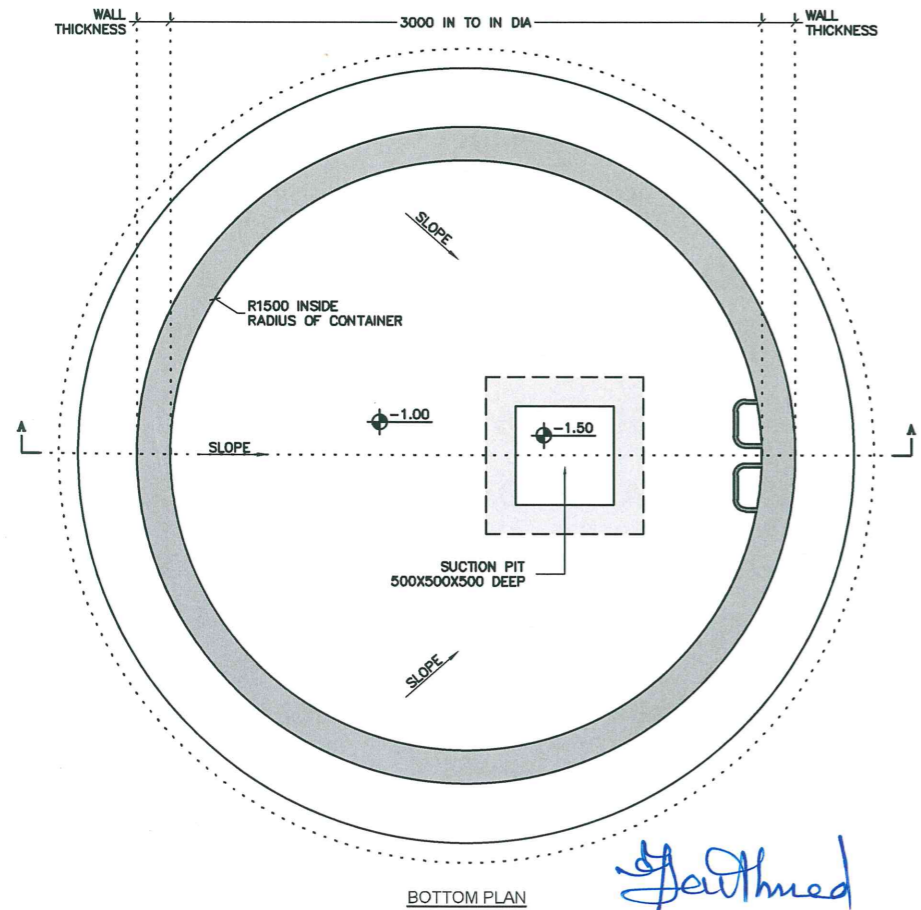
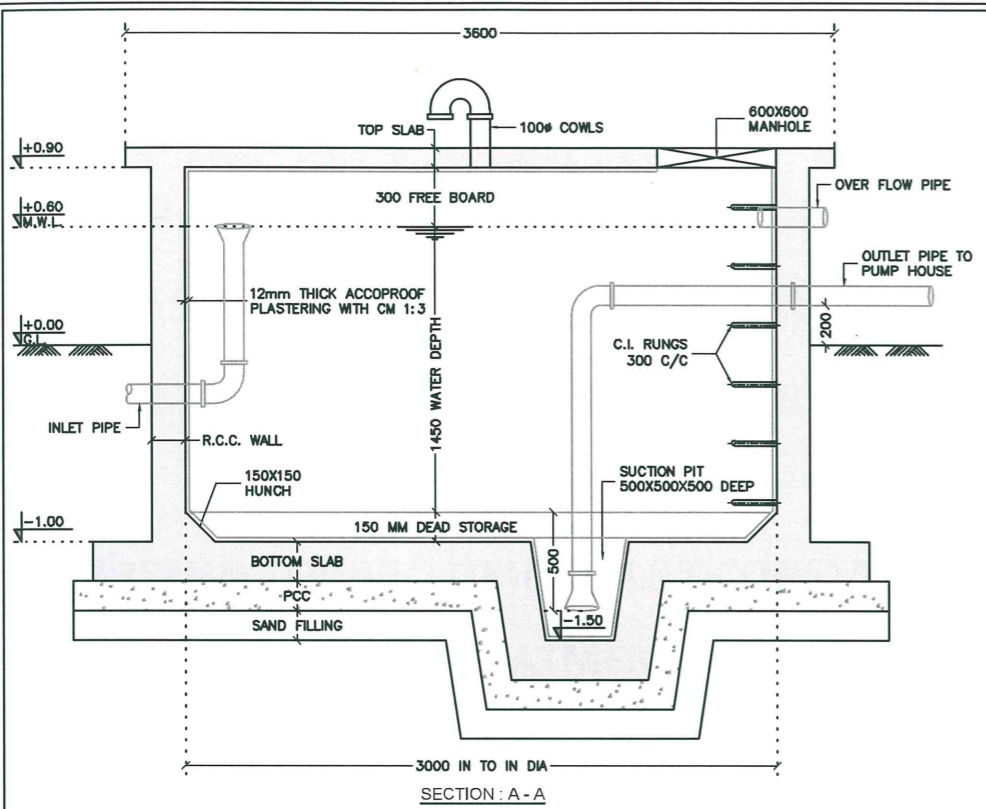

SCHEDULE OF PIPE	
INLET PIPE SIZE	-
OUTLET PIPE SIZE	-
OVER FLOW PIPE SIZE	-

NAME OF VILLAGE				
KOLAMGUDA	MADHARAMGUTTA	GOUNDUGUDA	GOVARGUDA	BABAPUR
DODDIGUDEM	OTTIGHAT	NAYAKAPPUGUDA	GOTTIGOUNDUGUDA	PAVUGUDA
OOTPALLI	BHEEM GUDA	KONDI GG	SOMIGUDA	ALIGUDA 3
NAYAKAPPU GUDA	PATHAGUDA	KANNEPALLY	RAJULAGUDA	KHILADIGAON

NOTES :
 <1> ALL DIMENSION ARE IN MM AND LEVELS ARE IN METER.
 <2> LOCATION OF SUCTION PIT SHALL BE DECIDED AS PER SITE CONDITION BEFORE EXECUTION
 <3> LOCATION & LEVELS OF INLET,OUTLET & OVERFLOW PIPE SHALL BE VARIFIED WITH ENGINEER INCHARGE BEFORE EXECUTION

APPROVED
 SE, NIRMAL



REV. No	DESCRIPTION	DATE	DESIGNED	DRAWN	CHECKED	APPROVED
A	FOR APPROVAL	02/02/16	-	PMD	RMM	-

REVISIONS

L&T Construction
 Water, Smart World & Communication.

CLIENT : RURAL WATER SUPPLY AND SANITATION DEPARTMENT, TELANGANA. CONSULTANT : -

PROJECT : PROVIDING DRINKING WATER TO HABITATIONS IN KOMARAMBHEEM ASIFABAD SEGMENT IN ADILABAD DISTRICT

SUPPLIER / CONTRACTOR : **L&T Construction**
 Water & Effluent Treatment SBG

JOB No. : LE150883 TITLE : 10KL CAPACITY SUMP AT DIFFERENT VILLAGE (GENERAL ARRANGEMENT DRAWING) SCALE 1:30

NAME	SIGN	DATE
DSGN	HMP	02-02-16
DRWN	PMD	02-02-16
CHKD	RMM	02-02-16
APPD	-	02-02-16

DRAWING No. LE150883-C-WS-RW-GA-1441 SIZE A3 REV. A
 COMP. DATA : P16-02_79-01-02 SHEET 2 OF 2

RELEASED FOR PRELIMINARY TENDER INFORMATION APPROVAL CONSTRUCTION

Asst. Executive Engineer TDWSP Asifabad
 Dy. Executive Engineer TDWSP Asifabad
 Executive Engineer TDWSP Asifabad